

LANDSIDE

LUGGAGE TROLLEYS
CARROS DE AEROPUERTO

Stainless steel
Acero inoxidable

BRAC

REF. A10002



Our most robust model with a sleek design
El diseño más robusto y elegante



Automatic self-adjusting brake
Freno automático auto-ajustable



Certificación Europea
European certification



Wheels: 1 swivel and 2 fixed. Ø 180 mm
PA, Natural Rubber

Ruedas: 1 giratoria y 2 fijas. Ø 180 mm
PA, Goma natural

Trolley advertising space: 568 x 430 mm
Medidas panel publicitario: 568 x 430 mm

Weight: 20 kg
Peso: 20 kg

Nominal load capacity: 250 kg
Capacidad de carga nominal: 250 kg



MATERIAL:
Stainless steel with electrochemical polishing
Carro: Acero inoxidable de pulido electroquímico

SURFACE TREATMENT:
TRATAMIENTO SUPERFICIES:

Electrochemical polished
Pulido electroquímico

Basket frame: Steel Q235, Chrome plated, stainless steel

Estructura de la cesta: Acero Q235, cromado, acero inoxidable.



Nesting distance: 270 mm (10 carts: 3470 mm)
Distancia de encajamiento: 270 mm (10 carros: 3470 mm)

BRAC

REF. A10002

Technical design

Dibujo Técnico

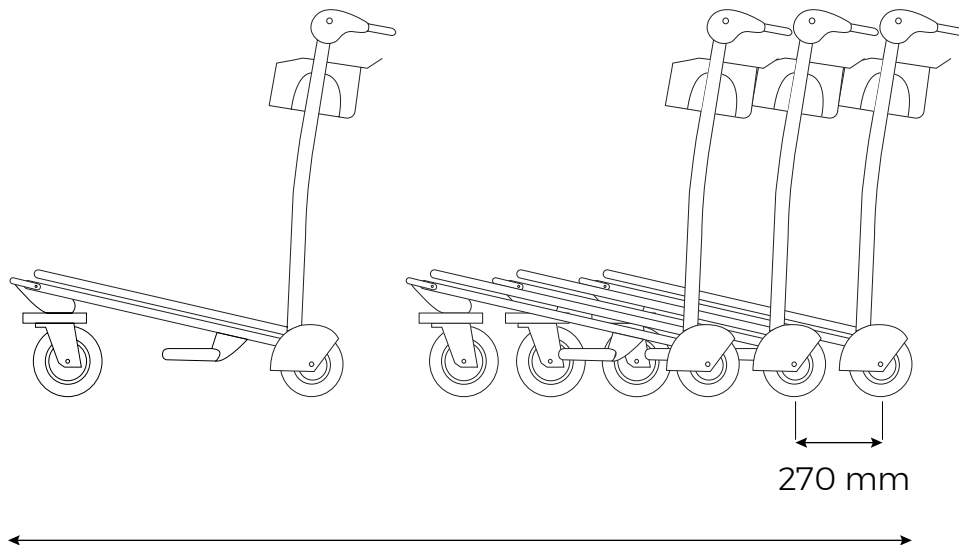
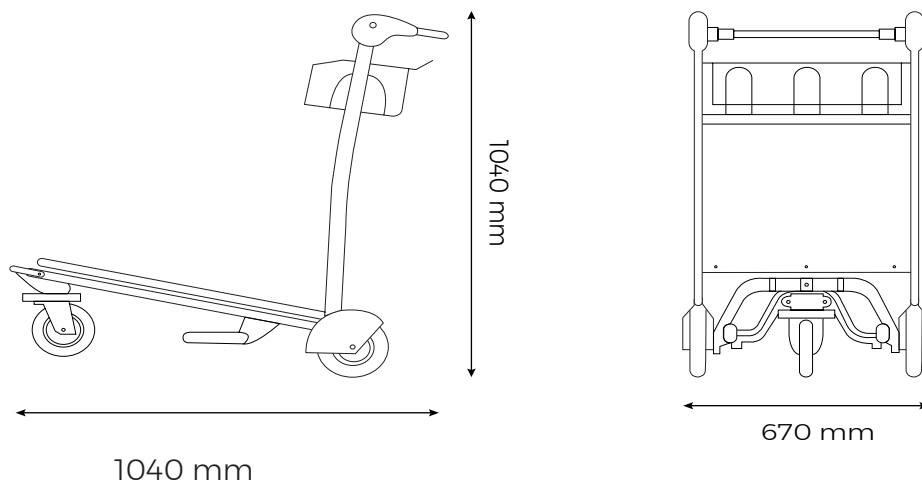

$$10PCS = 270 \times 9 + 720 = 3470 \text{ mm}$$